

Thank you for purchasing the **awave** brand series, which is a Atmos sound speaker specially designed for the non-destructive modification. They have all passed comprehensive tests to ensure its consistency and reliability.

- Before installing the mounting hole, please confirm that the installation space is appropriate.
- To prevent noise interference, make sure that the wiring is away from the engine, high voltage conductors and other potential sources of noise.
- To prevent short circuits, make sure that the wiring avoids moving parts and sharp edges.
- Before installing this product, please make sure that you have read this installation guide carefully.

ATM 2 TECHNICAL PARAMETERS:

MODEL	ATM 2
Maximum Power	25W
Speaker	1*1.8" 4 ohm
Frequency Range	165Hz~15K Hz
Sensitivity@ 1W/1M	83 dB
Box	Aluminum
Dimension (LxWxH)	Ø70 mm

Installation 1:

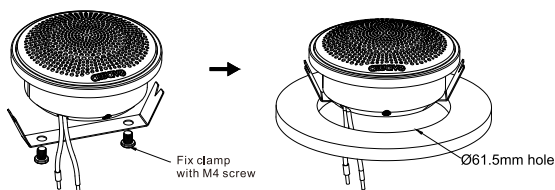

Installation 2:

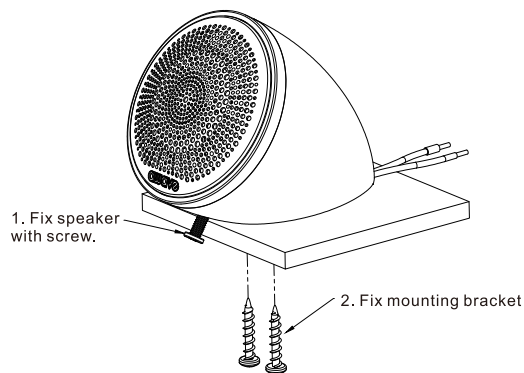

awave

ATM 2

ULTRA ATMOS SOUND SPEAKER
USER'S GUIDE

awave

ATM 2

天空声道音箱
快速使用指南

感谢您购买 **awave** 品牌系列产品，这是一款专门为汽车无损改装使用而设计的天空声道音箱，本产品已经通过全面的测试以确保其性能的一致性和可靠性。

- 在打安装孔之前，请确认安装空间是否合适。
- 为了防止噪音干扰，请确保接线远离发动机，高压导线和其他潜在的噪音来源。
- 为防止短路，请确保布线避开运动的部件和锋利的边缘。
- 在安装本产品之前，请确保您已经仔细阅读本安装指导。

ATM2 技术参数：

产品型号	ATM 2
最大功率	25W
喇叭尺寸	1*1.8" 4 欧姆
频率范围	165Hz~15K Hz
灵敏度	83 dB
音箱材质	铝
音箱尺寸（长x宽x高）	Ø70 mm

安装方式 1:

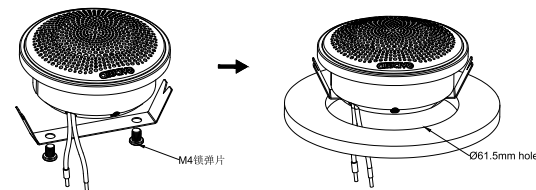

安装方式 2:

