

OWNER'S MANUAL

STEG



Italy

QK200.2

QK200.4

HIGH POWER MOSFET AMPLIFIER

INSTALLATION SPECIFICATION

Congratulations on purchasing the High Speed Power Amplifier. The amplifier has been designed using the latest electronic technology available, allowing you to produce high quality stereo reproduction in mobile applications. This system provides you with low harmonic distortion, a huge considerable amount of reserve voltage and high temperature stability.

Just enjoy the perfect sound this amplifier takes to you!

INSTALLATION

* Since the amplifier is sensitive to electrical and motor noise and interference from the amplifier may affect your radio reception, try to mount it at least ^{3 feet} ~~3 feet~~ away from the receiver. Good locations include under a seat, in the trunk or hat

* Please remember this is a high power unit which generates high electrical energy and heat. Therefore be sure to install the unit in a place with sufficient airflow, a minimum of dust and no moisture. Allow enough space around the cooling fins to permit reasonable airflow and cooling. It is important to ensure that the cooling fins of the heat sink are not against a panel or a surface preventing air circulation.

* Never mount the amplifier in a location that is subject to direct sunlight or exposed to moisture. Be sure to mount the amplifier to a strong, solid surface which will not give way under the stress of a sudden stop or accident.

* When mounting the amplifier on a side wall, try to position it so that the slots in the cooling fins are vertical. Amplifier should not be mounted on the bottom of a rear deck with the fins facing down because the heat will radiate back up into the amplifier. Leave yourself enough room on either side of the amplifier to make all the wire connections and adjust the controls. If you have a subwoofer box in your vehicle, you can mount the amplifier on the outside of the box.

Caution: *If you are mounting the amplifier to the vehicle's floor, check beneath the car to be sure your screws won't puncture a brake or gas line'*

WARNING!

Continuous exposure to sound pressure levels over 100dB may cause permanent hearing loss. High power autosound system may produce sound pressure levels well over 130dB, use common sense and practice safe sound please!

POWER CONNECTION

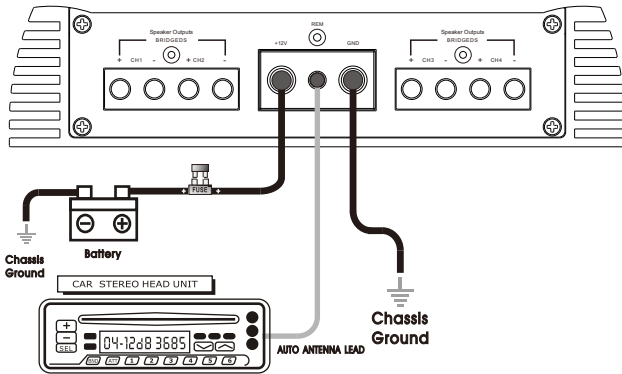

IMPORTANT! Before making any connections, disconnect the car's battery until the installation is completed to avoid possible damage to the electrical system

- * The +12V DC power cable should be heavy gauge stranded copper cable with heavy insulation, since it draws power directly from the positive battery terminal. Select the cable gauge at least 10mm^2 . And the ground cable gauge should be the same as the +12V DC.
- * Connect the +12V Power terminal to the battery (+) position terminal. An in-line fuse must be installed in the +12V power cable near the battery less than 50mm. **Without one**, an accidental short circuit could pose a fire hazard and damage your amplifier. Connect the fuse holder to battery, however, do not install fuse at this time.
- * Connect the GROUND Power terminal directly to the battery (-) position terminal or the car chassis. Ensure that all paint or other insulation is removed from around the hole area, and using self tapping screw, securely affix the bare wire ends to the vehicle chassis. Use as short as possible.
- * Many radio's and other music sources have an output terminal for connection of the remote turn on of the power amplifier. CONNECT the output terminal to the amplifier REM control jack. If a radio doesn't have a remote turn on feature, you can connect the REM pole to external switch for positive +12V ON/OFF.
- * To help minimize interference, it is best to run the power cables along the opposite side from the audio cables.

Caution: The power cables must be connected tightly. A loose connection may cause malfunctions or interference noise or distortion.

4 CHANNEL AMPLIFIER-FEATURES

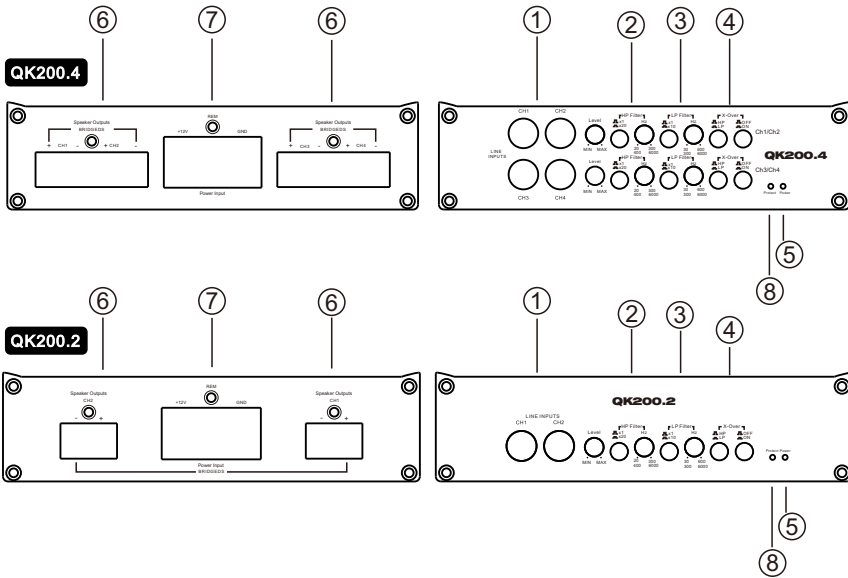

① Low-Level Input

The LINE INPUT RCA jacks must be connected with the RCA output jacks of the headunit

② HP filter

x1, Variable high pass filter from 20Hz to 300Hz
x20, Variable high pass filter from 400Hz to 6000Hz

③ LP filter

x1, Variable low pass filter from 30Hz to 600Hz
x10, Variable low pass filter from 300Hz to 6000Hz

④ X-OVER Switch

⑤ POWER ON LED

Lights up when the amplifier is energized indicating the unit is on

⑥ SPEAKER OUTPUT TERMINALS

⑦ POWER SUPPLY TERMINALS

⑧ PROTECT LED

Lights indicating the amplifier has gone into a protection mode

4 CHANNEL AMPLIFIER-APPLICATIONS

INPUT CONNECTIONS

* This amplifier has RCA connections for low level inputs. Low level signal is carried through RCA cables. It is preferred to use low level inputs to the amplifier if the head unit is equipped with the low level outputs.

SPEAKER OUTPUT CONNECTIONS

You do not need to make any adjustment for the input connection of amplifier before you connect the speaker output.

* Connect right and left speaker wire to corresponding speaker output terminals of the amplifier.

* Be sure to have the positive wire from the speaker to the positive speaker terminal of the amplifier and the negative wire from the speaker must connect with the speaker terminal of the amplifier. Reversing any of these connections will result in the speaker cones moving out of phase which causes bass cancellation.

LEVEL CONTROLS

Turn the VOLUME control on the amplifier to Min initially.

Once the initial power sequence has been performed, set the CD/RADIO volume control to roughly 80% of full. Insert a CD or tune to a radio station and slowly turn up the amplifier VOLUME control until you hear some distortion, and then back it off for clean sound.

4 CHANNEL AMPLIFIER-APPLICATIONS

QK200.2 QK200.4

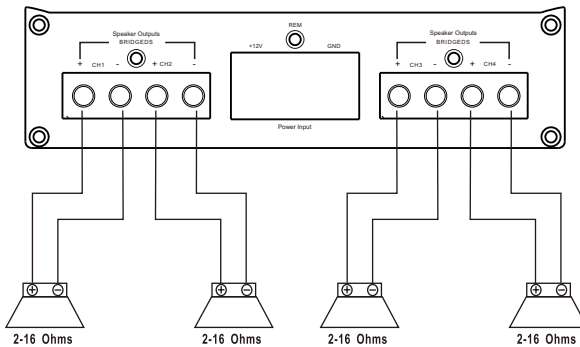
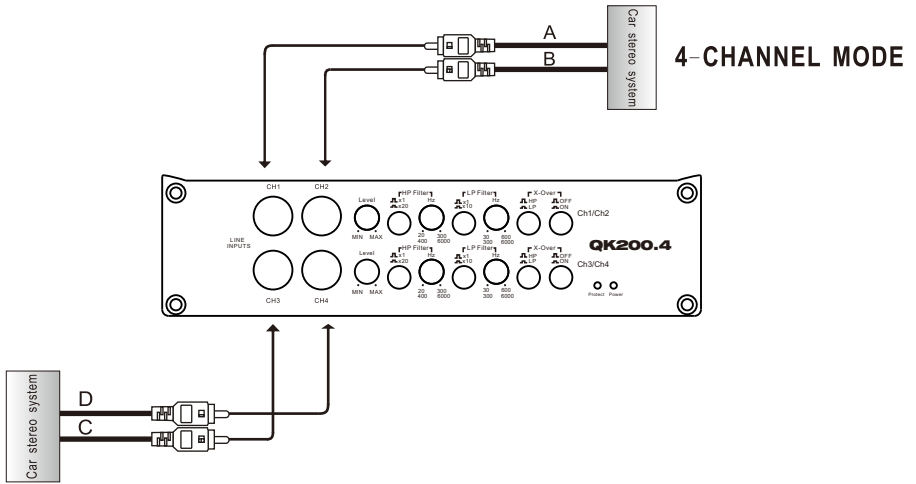

4 CHANNEL AMPLIFIER-APPLICATIONS

QK200.2 QK200.4

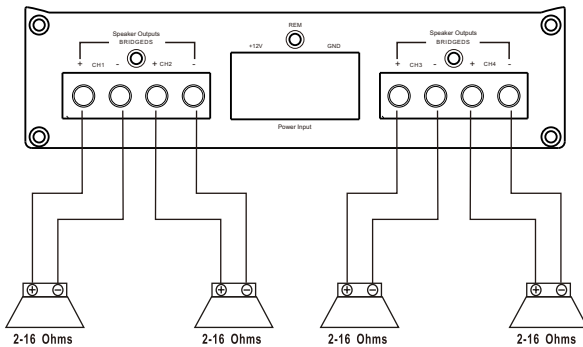
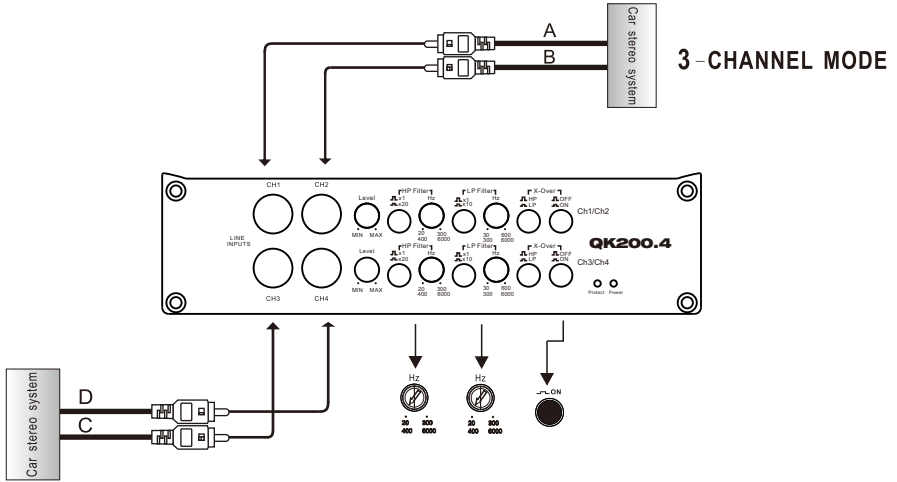

SPECIFICATION

	QK200.2	QK200.4
Output Power Rating @ 4 Ohms	2x200W	4x200W
@ 2 Ohms	2x300W	4x300W
@ 1 Ohms	—	—
Bridged @ 4 Ohms	1x485W	2x485W
Frequency Response	10Hz~30KHz	10Hz~30KHz
Input Sensitivity	0.2~8V	0.2~8V
Signal To Noise Ratio	>98dB	>98dB
THD&Noise	<0.01%	<0.01%
Low Pass Cross Frequency	30Hz~6KHz	30Hz~6KHz
High Pass Cross Frequency	20Hz~6KHz	20Hz~6KHz
Subsonic Filter	—	—
Bass EQ	—	—
Speaker Impedance	2~8 Ω	2~8 Ω
Dimensions (L×H×W) mm	302X64X207	394X64X207

*All specifications subject to change without notice

安装规范

感谢购买此款高速功率放大器！

此款放大器具备最先进的电子技术，您能在车内随心所欲去追求最佳的播放音质。该放大器以其低工作电流，快速转换能力，低失真因数和极为出色的恒温性能成为出类拔萃的音响器材精品。

用心感受这款放大器给您带来的听觉享受吧！

在安装和使用放大器之前,请您先认真阅读安装说明书。

- * 由于这款放大器对电子和发动机的噪音很敏感,为了不影响收音机接收,尝试让它与接收器至少有3尺距离,座位底下,汽车后备箱或者汽车舱门区域,都是最佳位置。
- * 请切记这是大功率放大器,能产生高电平和高热量,所以在要在一个空气流通,干净且干燥的地方来安装放大器装置。如果条件允许,请在风扇冷却散热器周围留下足够的空间来保持空气流通和制冷,为了空气流通,确保散热片不会被其他物品阻挡。
- * 禁止让放大器直接在阳光下暴晒或者放置在潮湿处。请将放大器放置在一个牢固的位置,避免汽车在行驶途中遇到事故或者急刹车的时候放大器会跟随移动。
- * 当装置放大器在靠墙边的时候,让散热片保持垂直向上;请勿将放大器放置在后备箱和散热片端口不能朝下,因为热量将会倒回流入放大器里。在放大器旁边留下足够空间来使全部线材连接正确。如果您的汽车有一个超低音音箱,您可以装置放大器在该音箱的外面。

注意:若您把放大器装置在汽车底部,请检查车辆的底部螺丝,确保在遇到急刹车时候放大器没有被刮坏。

温馨提示

播放的声音持续保持在100dB及以上可能会导致听力的损害。压力超过130dB的大功率汽车音频系统将会对声音带来一定压力,请使用普遍和习惯性的听力范围。

电源连接

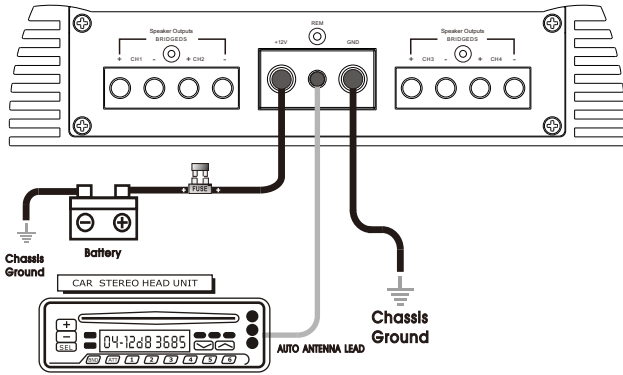

重要!在进行任何连接之前, 为了避免对汽车电气系统造成伤害, 请断开汽车的电池直到所有的安装完成为止。

+12V所使用的电线必须是高规格的镀铜绝缘线材, 因为它与电源的正极末端直接连接。线材横截面面积至少在 10mm^2 。接地的电线需与+12V的一致。

+12V与电源的正极末端直接连接。保险装置在距离+12V电源和电池至少50mm的地方, 若无保险, 突发的短路将可能会造成起火, 损坏您的放大器。请安装好电源后再装保险。

GND的末端与电池的负极末端或者汽车底盘连接。把孔位上的油漆及其他装饰物去掉, 使用同一款开孔螺丝, 把露出的电线安全地固定在汽车的地盘。

为了方便放大器的线控工作, 有些收音机或者其他音乐设备有一个输出装置。如有此功能, 把输出末端与放大器的REM连接; 如果没有, 则把REM与+12V的开关连接。

为了减少接触面, 最好把电源线放置在音频的对立面。

注意: 电源线必须连接牢固稳定, 若有松散, 可能会引起故障或者是噪音干扰和失真。

4声道放大器的特征

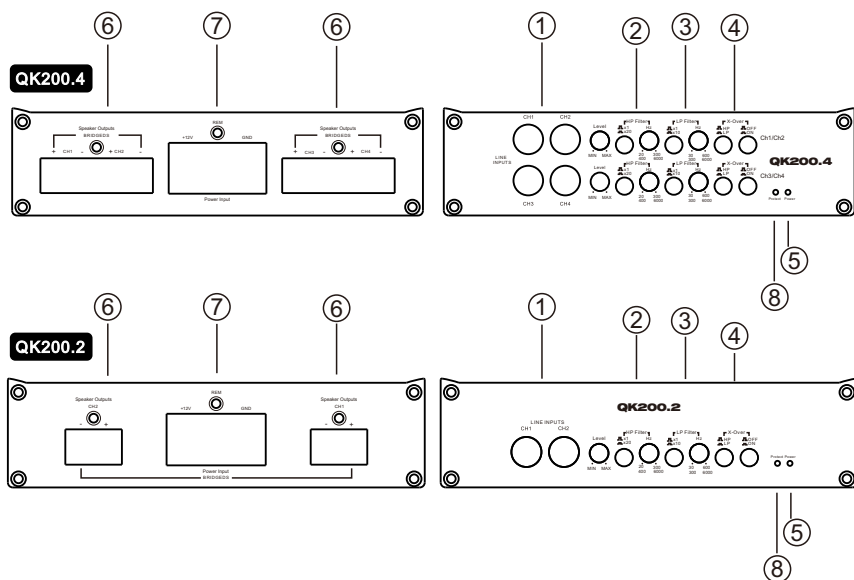

- ① 线路输入
必须与RCA输出连接
- ② 高通频率调节
x1, 频率范围从 20Hz 至 300Hz
x20, 频率范围从 400Hz 至 6000Hz
- ③ 低通频率调节
x1, 频率范围从 30Hz 至 600Hz
x10, 频率范围从 300Hz 至 6000Hz
- ④ X-OVER 开关
- ⑤ 电源指示灯
若电源指示灯亮, 即放大器开始启动
- ⑥ 输出终端
- ⑦ 电源端子
- ⑧ 电源保护灯
若保护指示灯亮, 即出现故障

4声道放大器的应用

输入连接

此款功放的低电平输入有RCA插口，通过RCA线传送低电平信号。如果主机产生低电平输出时，功放会启动低电平输入。

喇叭输出连接

- * 在连接喇叭输出之前，您无需对放大器的输入连接做任何调整。
- * 正确连接喇叭线材到功放喇叭输出线排。
- * 正确连接喇叭的正极负极到功放喇叭输出线排。若正负极连接错误可能会使相位移动，从而导致低音的消除。

输入电平调节器控制

首先把功放的音量控制调到最小。

当功放的音量调节好顺序之后，把CD或收音机的音量调到主机最大音量的80%，之后放入CD碟或者调好收音机频道，慢慢调大功放的音量直到你听到些许声音失真，这时慢慢调小音量直到你听到清晰的声音即可。

4声道模式

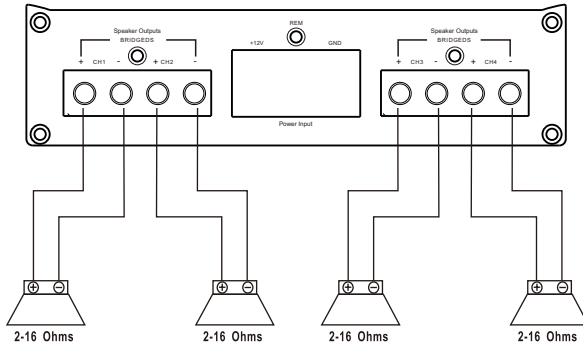
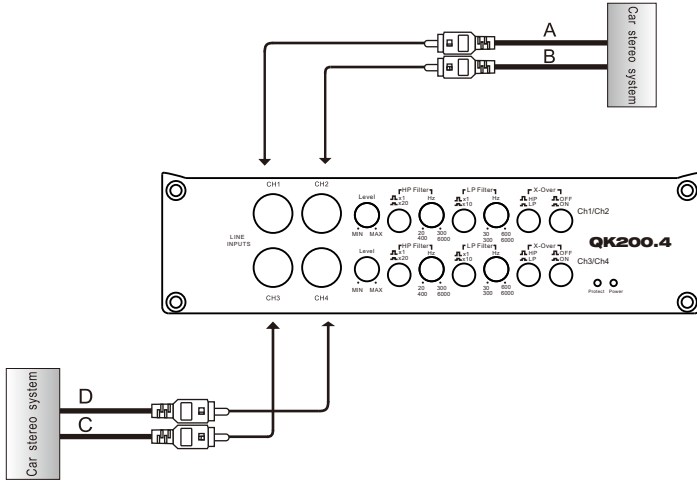

3声道模式

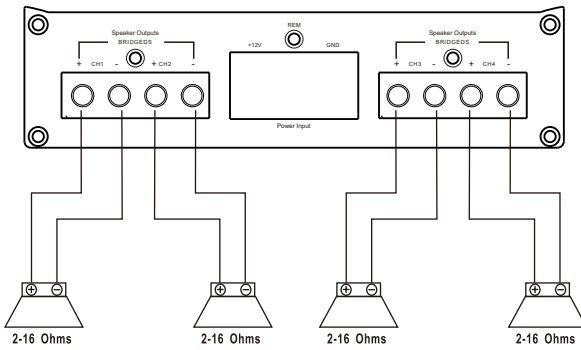
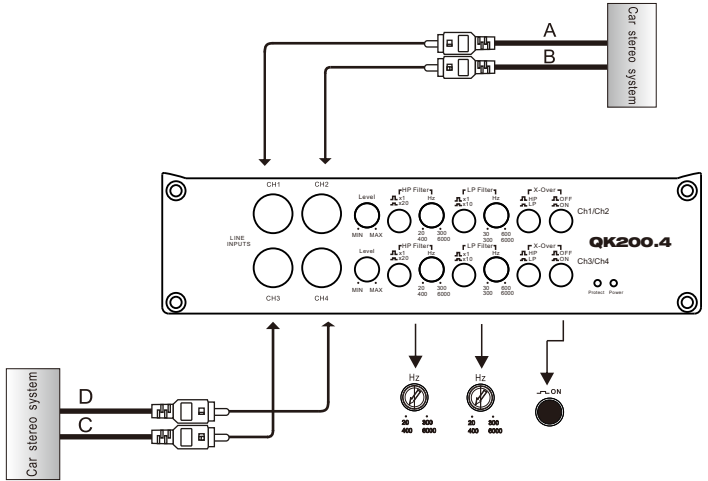

参数规格表

	QK200.2	QK200.4
输出功率在4欧	2x200W	4x200W
在2欧	2x300W	4x300W
在1欧	—	—
桥接在4欧	1x485W	2x485W
频率响应	10Hz~30KHz	10Hz~30KHz
输入灵敏度	0.2~8V	0.2~8V
信噪比	>98dB	>98dB
失真度	<0.01%	<0.01%
低通滤波器	30Hz~6KHz	30Hz~6KHz
高通滤波器	20Hz~6KHz	20Hz~6KHz
次低音滤波器	—	—
低音提升	—	—
独立输出	2~8 Ω	2~8 Ω
尺寸规格(长X高X宽)毫米	302X64X207	394X64X207

*可能做技术改动