



# **WDX 2K**

**WDX12 2K**

**WDX15 2K**

## **USER MANUAL**

Installation Instructions | Owners Manual

Due to continuous improvement of the product, specifications are subject to change without notice.

## Introduction

Congratulations on your purchase of a DB Drive state-of-the-art subwoofer. Your selection of a DB Drive car audio product indicates a true appreciation of fine musical reproduction. Whether adding to an existing system or including your DB Drive subwoofer in a new system, you are certain to notice immediate performance benefits.

## Keep Your Sales Receipt

Take this time to attach your sales receipt to the manual and put in a safe place. In case of any unforeseen reason this product may need warranty service, your receipt will be necessary to establish purchase date.

## Recommendation

A power subwoofer's performance is only as good as its installation. Proper installation will maximize the system's overall performance. It is recommended that you have our product installed by an authorized DB Drive retailer. However, if you decide to install it yourself, please carefully read through this manual and take your time to do a quality installation.

### **IMPORTANT!**

Before making any connections, disconnect the car's battery until the installation is completed to avoid possible damage to the electrical system.

### **WARNING!**

Exposure to high power sound system can cause hearing loss or damage. Listening to your system at loud levels while driving will impair your ability to hear traffic sounds and emergency vehicles. Use common sense when listening to your system.

Serial # \_\_\_\_\_ Model # \_\_\_\_\_

# PRODUCT SPECIFICATIONS

## TS SPECS

	WDX12 2K	WDX15 2K
Resonant Frequency ( <b>fs</b> )	44.9 Hz	35.9 Hz
DC Resistance ( <b>Re</b> )	3.6 Ω x 2	3.6 Ω x 2
Coil Inductance ( <b>Le</b> )	3.13 mH	3.09 mH
Mechanical ( <b>Qms</b> )	4.08	4.14
Electromagnetic ( <b>Qes</b> )	0.67	0.80
Total Q ( <b>Qts</b> )	0.58	0.67
Compliance Equivalent Volume ( <b>Vas</b> )	18.8L	46.6L
Mechanical Compliance of Suspension ( <b>Cms</b> )	0.05 mm/N	0.04 mm/N
BL Product ( <b>Bl</b> )	26.7 N/A	26.7 N/A
Diaphragm Mass inc. Airload ( <b>Mms</b> )	235.6 gr	438.1 gr
Sound Pressure Level ( <b>SPL</b> )	85.9 dB	86.1 dB
<b>X-Max</b>	12.5mm	12.5mm

# CALCULATING ENCLOSURES

It is recommended to build your enclosure from at least 3/4" thick MDF (medium density fiberboard). Make sure the enclosure is sealed airtight.

## Calculating External Volume

To calculate box volume, measure the outside Width x Height x Depth of the enclosure. *Example 12" x 14" x 9" = 1512 ÷ 1728" Cubic feet*

Next you must convert cubic inches into cubic feet. To do this, you must divide the cubic inches total by 1728". *Example 1512 ÷ 1728 = .875 Cubic feet*

## Calculating Internal Volume

To calculate the internal (net) volume of the above box you must first multiply the thickness of the wood you are using by Two. *Example 3/4" x 2 = 1.5"*

Next subtract 1.5 from each of the outside measurements of the box.

<i>Width</i>	<i>Height</i>	<i>Depth</i>
12 - 1.5 = 10.5	14 - 1.5 = 12.5	9 - 1.5 = 7.5

Multiply the new totals (**H x W x D**) *Example: 10.5 x 12.5 x 7.5 = .5696*

Next you must convert cubic inches into cubic feet. To do this, you must divide the cubic inch total by 1728". *Example 984.375 ÷ 1728 = .5696 cubic feet*

# RECOMMENDED ENCLOSURES

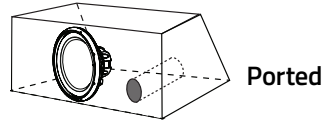
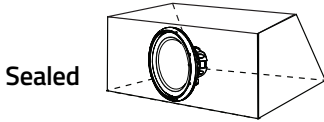

## WDX12 2K

### Sealed Enclosure

Box Volume: 2.0 cu ft. / 56.63L

### Ported Enclosure

Box Volume: 2.7 cu ft. / 76.45L

Box Turning: 39Hz

Port Area: 30 sq in. / 193.55 cm<sup>2</sup>

Port Length: 12 in / 30.48 cm

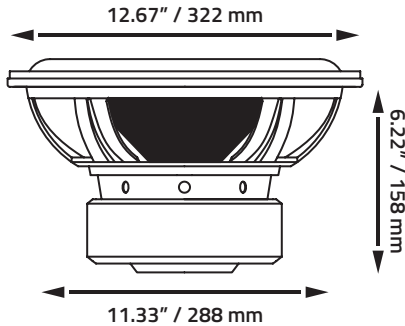

## WDX15 2K

### Sealed Enclosure

Box Volume: 3.0 cu ft. / 84.95L

### Ported Enclosure

Box Volume: 3.4 cu ft. / 96.27L

Box Turning: 39Hz

Port Area: 40 sq in. / 258.06 cm<sup>2</sup>

Port Length: 18 in / 45.72 cm

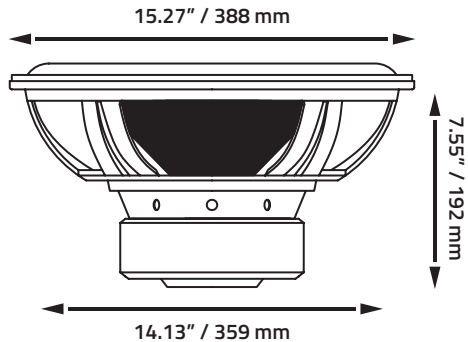

DB Research L.L.P.

302 Hanmore Industrial Parkway Harlingen, TX 78550

Phone (877) 787-0101 : Fax (956) 421-4513 : [www.DBDrive.net](http://www.DBDrive.net)